



- INSTRUCTION SHEET -
SUPPORTER X2 (VEHICLE STABILIZER) W/ EXTENSION

PN: 22-797E12E

COMPONENT TECHNICAL DATA:

OVERALL LENGTH:	RETRACTED, 40 IN / 101.6 CM EXTENDED, 65.4 IN / 166.1 CM EXTENDED WITH EXTENSION 95.4 IN / 242.3 CM
TOTAL WEIGHT:	15.9 kg (35.0 lbs)
MAX AXIAL LOAD:	4,535 kg (10,000 lbs) AT 2:1 SAFETY FACTOR

FIGURE 1

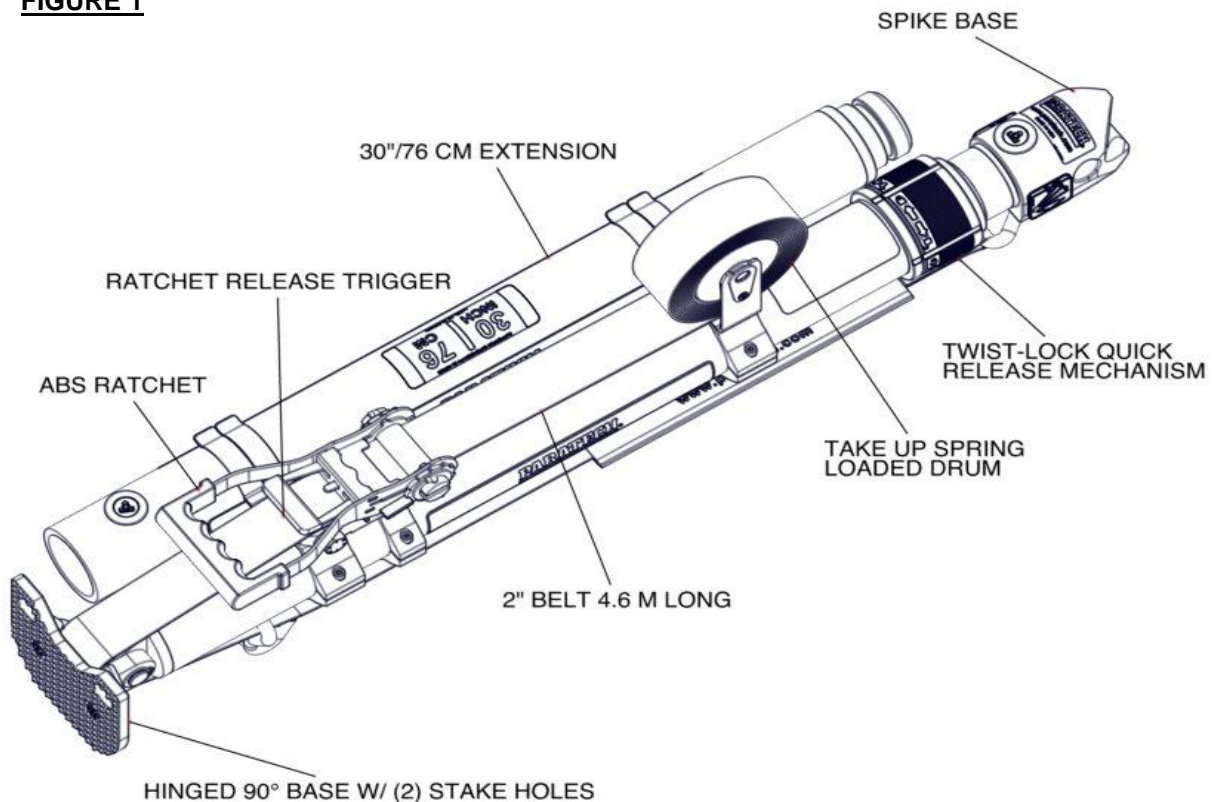

Paratech Incorporated
P.O. Box 1000, Frankfort, IL 60423 USA
Customer Service: 800.435.9358
Paratech@paratech.dk
Phone: 815.469.3911 Fax: 815.469.7748
www.paratech.com E-mail: paratech@paratech.us

Paratech Europe, Branch of Paratech Inc.
P.O. Box 174, 5260 Odense S, Denmark
www.paratech.com Email:



FIGURE 2

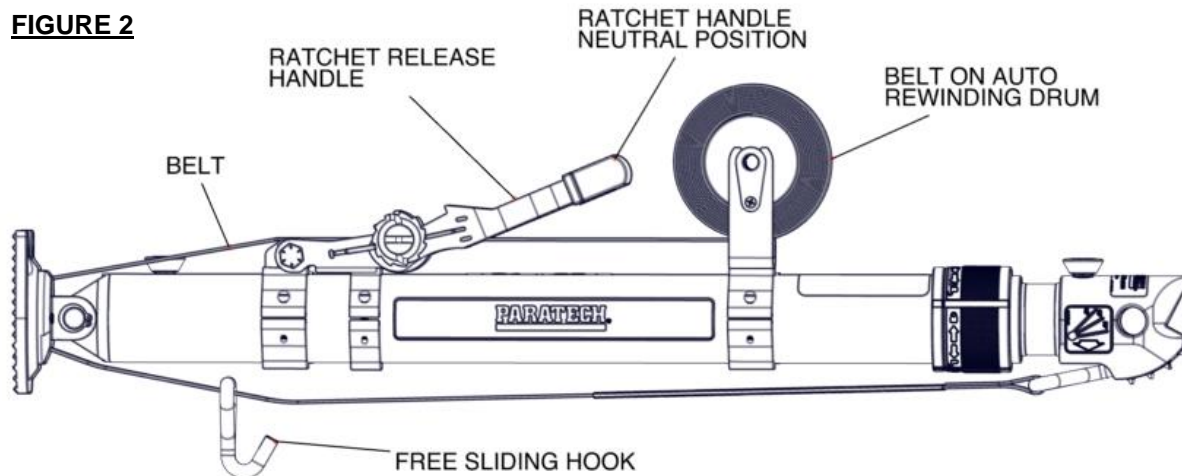

RATCHET BELT OPERATION WITH “ANTI-BELT SLIP” (ABS) OPTION:

NOTE: The ABS system lets you release the pre-tension force in small steps.

1. Pull the ratchet release trigger, open the ratchet handle fully and release the trigger. This locks the ratchet handle in the neutral position 4 and allows the belt to move freely through the ratchet mechanism, see Figure 2 & 3.
2. Pull out the desired length of belt from the base end of the device and attach the free sliding hook, if required, to desired position on the car, Figure 5.
Note: Belt is under tension due to auto-rewinding drum.
3. To adjust the belt tension, pull up the trigger and rotate the handle into belt tensioning position 1, moving the ratchet handle forward and backward within position 1 will increase the belt tension systematically until the desired tension is achieved. Move the ratchet handle back to locked position 3 after tensioning, Figure 3.
4. To release tension off the belt, pull the release trigger up and rotating the handle into the controlled release position 2 and release the trigger, Figure 3.
5. The tension is released by moving the handle forward and backward within position 2. Release occurs in small increments with every stroke of the handle, Figure 3.
Note: Controlled release is only applicable when there is a load on the belt.
6. To free the belt, pull the release trigger up and rotating the handle into neutral position 4. The ratchet is now fully open and the belt can be pulled free through the ratchet mechanism, Figure 2 & 3.

FIGURE 3

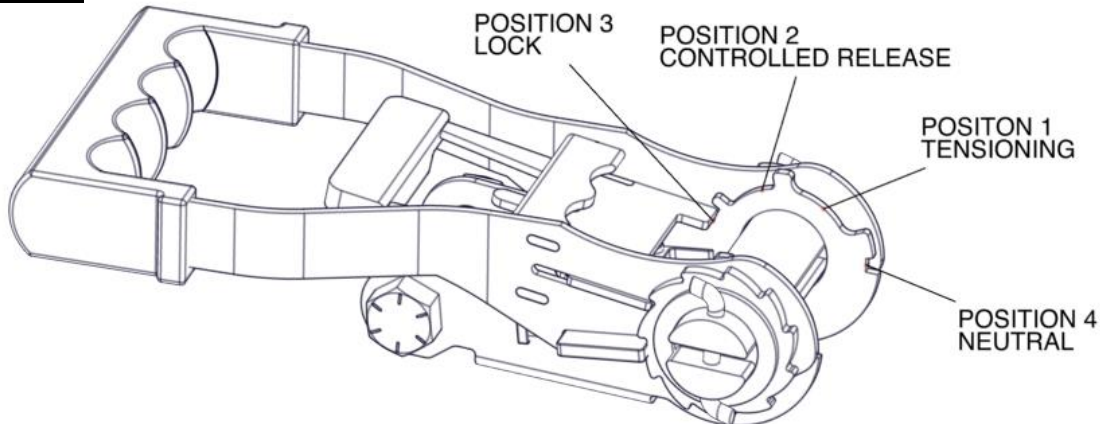

STABILIZER OPERATION:

1. Place one hand on the knurled TwistLock Collar and another hand on the Spike Base, see Figure 4.
2. Unlock the TwistLock Collar by rotating it counter-clockwise (⌚ - label direction) until it stops, approximately 45°. This disengages interlocking teeth on the shaft.
3. Adjust the strut length (extending/retracting the shaft) to position the Spike Base at the designated point of contact on the vehicle.

Note: The strut length only needs to be approximate to the insertion point on the vehicle with the Supporter leaning into the vehicle at roughly 45° - 60° (45° being ideal); see Figure 4.

4. With both hands still in place, turn back the TwistLock mechanism clockwise (⌚ - label direction) until the red, lock indicator stripes are aligned.

WARNING: The TwistLock mechanism is spring loaded and may return on its own; however, the operator must always physically rotate the mechanism back to be sure the interlocking teeth have fully re-engaged.

5. Move the Supporter into the desired position on the vehicle placing the Spike Base in place first.
6. As shown in the "RATCHET BELT OPERATION" section above, release the ratchet belt and attach the free sliding hook to the bottom of the vehicle. Tie-Down Keys can be used to facilitate a connection between the vehicle and ratchet belt hook as required.
7. Tighten the ratchet belt until the Supporter is securely in place and lock the ratchet handle.
8. Stake the base plate into position with pickets as required (each hole $\text{Ø} = 1" / 25.4 \text{ mm}$).
9. To remove the Supporter, reverse steps 1–6.

FIGURE 4

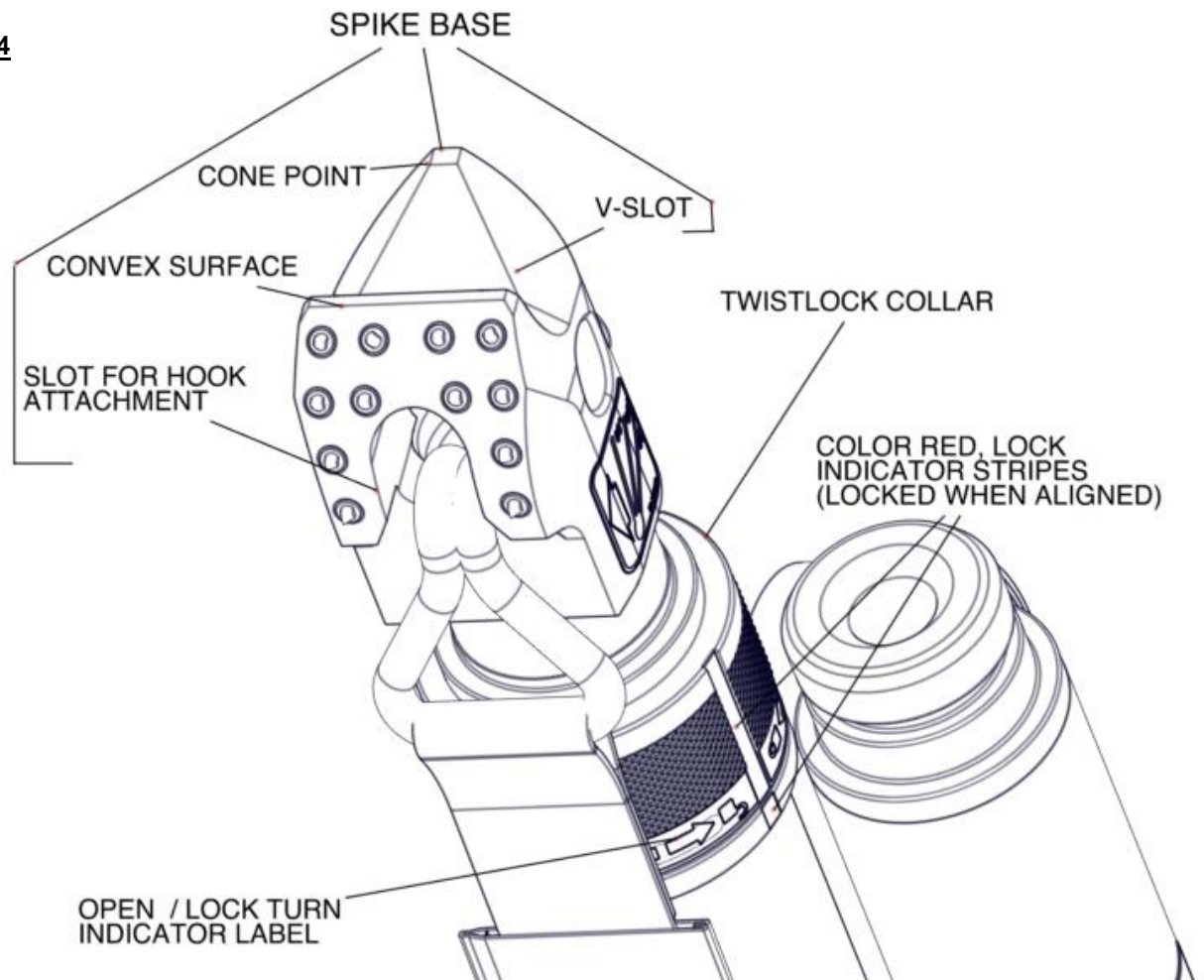
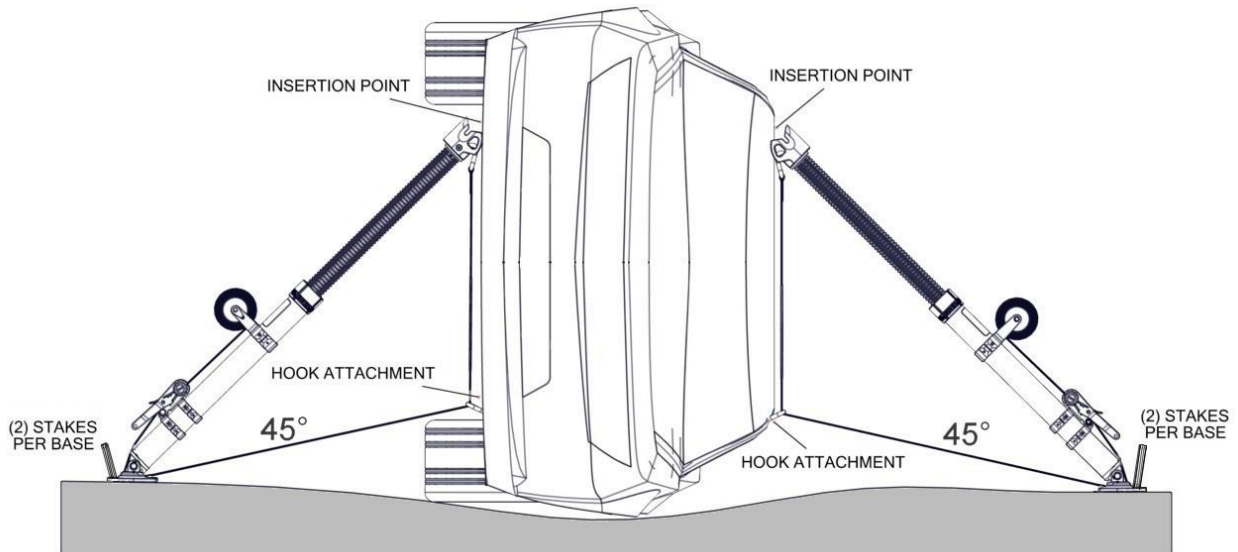

FIGURE 5

This is an illustration of an ideal vehicle stabilization using two Supporters. Note the optimal 45° angle between the stabilizers, ground, and vehicle. Supporter bases and ratchet belt hooks are attached to the vehicle frame and rigid body area as shown. The ratchet belt is in the locked position.



OPTIONAL:

STAKE BASE INTO POSITION USING PICKETS THROUGH THE TWO HOLES, EACH Ø 25.4 MM (1") ARE PROVIDED IN THE HINGED BASE.

LOAD RATING:

The Supporter rating of 4,535 kg (10,000 lbs) with a 2:1 Safety Factor is based on pure axial loading. Offset axial loading reduces the rated capability as follows:

- V-Block = 4,082 kg (10,000 lbs) with 2:1 Safety Factor
- Convex Edge = 3,628 kg (8,000 lbs) with 2:1 Safety Factor
- Cone Point = 2,267 kg (5,000 lbs) with 2:1 Safety Factor

TOOL MAINTENANCE:

- Periodically lubricate TwistLock mechanism (Paratech recommends Teflon Non-Stick Dry-Film Lubricant) and keep free of dirt and debris.
- Replace worn, frayed, or cut ratchet belt as required.
- To clean, wipe all exposed surfaces with warm water and soft cloth.

EXTENSION PN 22-797680

USE 76 cm (30") SUPPORTER EXTENSION (supplied w/each SUPPORTER X2) if necessary.

(NOTE: This is a custom Extension and this Supporter does not accept other Paratech Strut Extensions). To use it, remove the Spike Base, install Extension and attach Spike Base on the end of the Extension tube.

PARTS LIST:

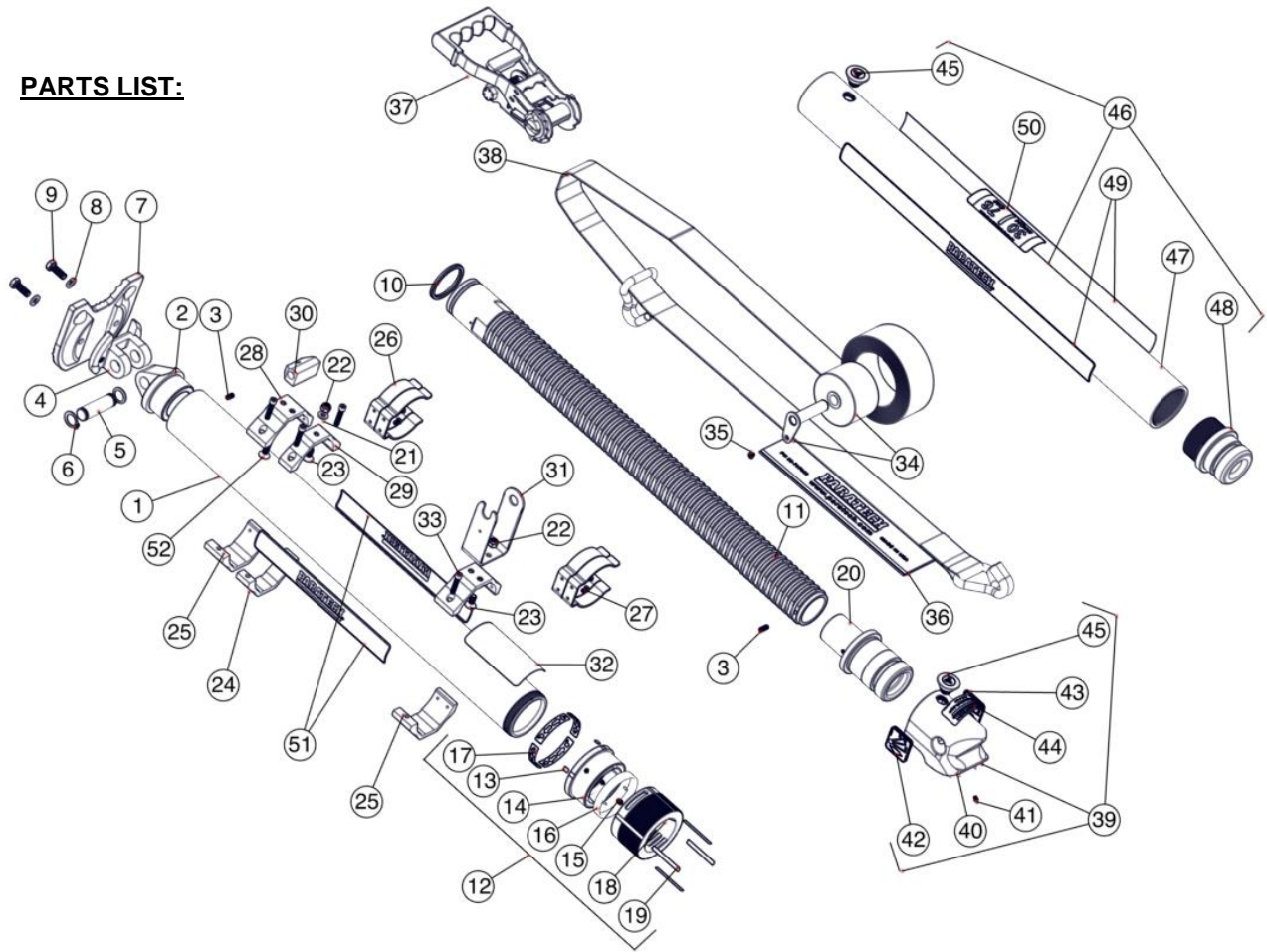

ITEM	QTY	PN	DESCRIPTION
1	1	22-797078	TUBE, SUPPORTER
2	1	22-797076	CLEVIS MALE, SILVER, SUPPORTER
3	2	22-895292	SET SCREW 1/4-20 X 1/2" CUP SS
4	1	22-797057	FEMALE CLEVIS, SILVER, RATCHET
5	1	22-797077	PIN, CLEVIS, SUPPORTER HINGE BASE
6	2	22-796148	RET RING EXT 3/4" SHAFT H. SECT
7	1	22-797079	6" BASE PLATE, SUPPORTER
8	2	22-796088	3/8" LOCK WASHER SS
9	2	22-670553	SCR 3/8-16 X 1" HEX HD GR8 PLAT
10	1	22-796018	SEAL 2.5"O.D. 2.125" I.D. X 3/16
11	1	22-797074	SHAFT, SUPPORTER
12	1	22-797030N	TVS MECHANISM ASSY, SILVER:
13	4	22-797033	REFL STRIPE FOR TVS, SHORT
14	1	22-797032N	BASE RING, TWIST MECH, SILVER
15	2	22-797037	GUIDE SCREW 1/4-28 SS
16	1	22-797038	TORSION SPRING, STABILIZER
17	4	22-797039	LABEL FOR TWIST LOCK RING
18	1	22-797036N	TWIST LOCK RING SILVER
19	4	22-797035	REFL STRIPE FOR TVS, LONG
20	1	22-797087	SHAFT END ADAPTER, SUPPORTER
21	1	22-797083	GUIDE WASHER, RATCHET MTG
22	3	22-015716	LOCK NUT 5/16-18 NYL INS SS
23	3	22-670472	SCR 5/16-18 FLSCH X 3/4 SS
24	1	22-797043B	MTG BRKT - BOTTOM, RATCHET
25	2	22-797067C	MTG BRKT BOTTOM, DRUM
26	4	22-796182A	CLIP 3 IN

ITEM	QTY	PN	DESCRIPTION
27	8	22-670037	10-24 X 3/8 BUT SOCHD SCR SS
28	2	22-797068C	MTG BRKT - TOP, DRUM
29	1	22-797043T	MTG BRKT - TOP, RATCHET
30	1	22-797084	OFFSET BLOCK, 2" RATCHET MTG
31	1	22-797064	POST BRKT FOR DRUM
32	1	22-797E12L	LABEL, SUPPORTER
33	4	22-670558	1/4-20 X 1.25 SCH CAP SCR SS
34	1	22-797063	Q-LOADER DRUM W/PIN SET
35	1	22-670033	#10-32 X 1/4" PHIL FL HD SCR SS
36	1	22-797058	HEAT SHIELD FOR STRAP
37	1	22-797066ABS	ABS RATCHET MECH, 2" BELT
38	1	22-797086	2" BELT 15 FT W/2 HOOKS
39	1	22-797687	SPIKE BASE ASM
40	1	22-797683	SPIKE BASE DET
41	12	22-797686	SPIKE 1/4" LG W/12-32 THD STL
42	1	22-797683L	LABEL, SPIKE BASE LEFT
43	1	22-797683R	LABEL, SPIKE BASE RIGHT
44	1	22-890981	PARATECH LABEL 1.25X
45	1	22-797775	LOCK PIN DOME, ASM
46	1	22-797680	SUPPORTER 30" EXTENSION
47	2	22-796681	SUPPORTER EXT TUBE
48	2	22-797682	SUPP EXT TUBE END
49	1	22-796208	LABEL Ø3.0 STRUT 21" STRIPE
50	1	22-797680L	LABEL FOR SUPP EXTENSION
51	2	22-796207	LABEL Ø3.0 STRUT 11" STRIPE
52	1	22-550082	SCR 5/16-18 FLSCH 7/8GR8 W/NYL

SUPPORTER X2 LIMITED WARRANTY

Each **SUPPORTER X2** or component thereof, manufactured by Paratech Incorporated, has been thoroughly inspected and properly adjusted before shipment to insure the highest quality and the greatest possible reliability.

Paratech Incorporated (hereinafter referred to as "Seller") hereby warrants the **SUPPORTER X2** or component thereof to the original retail buyer only against defects in material and workmanship under normal use and service for a period of five years on the **SUPPORTER X2** mechanism and one year on the **Ratchet** mechanism from the date of purchase. There is no warranty on the **BELT**. This warranty shall constitute the sole warranty of the Seller with respect to the **SUPPORTER X2** or component thereof. **THE SELLER HEREBY DISCLAIMS AND EXCLUDES ALL OTHER WARRANTIES, EXPRESSED OR IMPLIED, INCLUDING ANY IMPLIED WARRANTY OR MERCHANTABILITY OR FITNESS FOR A PARTICULAR PURPOSE.** The Seller neither assumes nor authorizes any other person to assume for it any other obligations or liabilities in connection with the sale or use of this product.

Should there be any defects in the material or workmanship of the **SUPPORTER X2**, buyer should return the defective product to the factory for inspection with shipping prepaid within one year from the date of purchase. If inspection shows that the **SUPPORTER X2** or a component thereof is defective and that such defects were not caused by negligence, misuse, accident or unauthorized service, the product sold hereunder will be repaired or replaced at the option of the Seller, without charge, FOB at the factory, Frankfort, Illinois.

THIS REMEDY SHALL BE THE EXCLUSIVE REMEDY FOR BREACH OF WARRANTY WITH RESPECT TO THE SUPPORTER X2 OR COMPONENTS THEREOF. THE SELLER SHALL NOT BE LIABLE FOR INCIDENTAL OR CONSEQUENTIAL DAMAGES RESULTING FROM ANY BREACH OF WARRANTY WITH RESPECT TO THE SUPPORTER X2 AND COMPONENTS THEREOF FROM ANY DELAY IN THE PERFORMANCE OF THE REMEDY HEREUNDER.

PARATECH®

PARATECH INCORPORATED
P.O. BOX 1000
1025 LAMBRECHT ROAD
FRANKFORT, ILLINOIS 60423-7000

TELEPHONE (815) 469-3911
FAX (815) 469-7748