

## INSTRUCTION SHEET G3 DUAL DEADMAN 250 PSI RSS CONTROLLER P/N: 22-796103G3

### FEATURES:

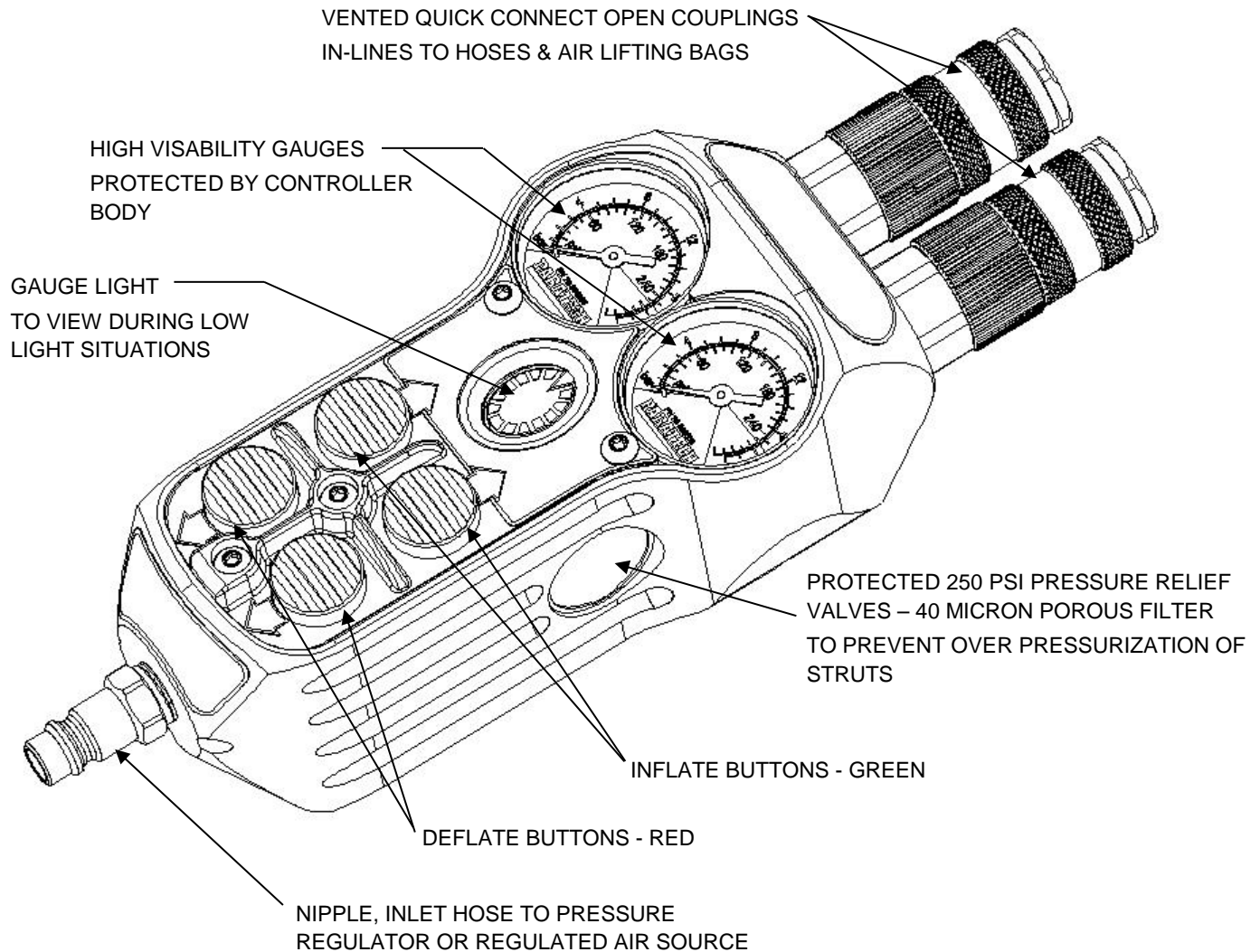

## **OPTIONAL COMPONENTS:**

1. GAUGE, PN 22-890603: Back mount 1.5" (38.1 mm) with 250 psi (17.2 bar) yellow scale and 250 – 300 psi (17.2 – 20.7 bar) red scale. Used to monitor system pressure, the gauge is installed inside the controller housing, see maintenance section for installation procedure. Gauge weight, .20 lbs. (.09 kg).



2. G3 Deadman Gauge Light, PN 22-890862: Ultra bright white LED flashlight with black polyurethane housing and PARATECH logo. IPX-7 rated with 3 minute timer mode to enhance battery life, see maintenance section for installation procedure. Gauge Light Weight .02 lbs. (.01 kg.)

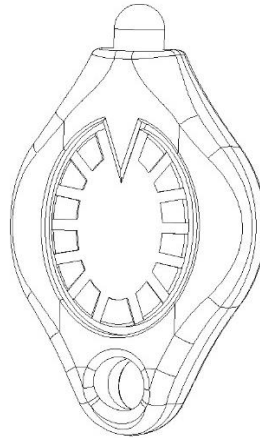

## **BASIC SAFETY PRECAUTIONS:**

- Equipment operation must always be conducted by trained personnel.
- All personnel at the immediate site must be properly suited up (protective clothing, helmet, eye protection, gloves, footwear, etc.) at all times.
- Follow instructions for full system set-up, operation, and teardown in the RSS Manual.
- To avoid the possibility of serious injury or death, stay clear of the loads and keep others away.
- Do not exceed the rated capabilities of the Strut, Controller, or Hose. Excess pressure may result in personal injury.
- Low pressure compressed air can be used to assist a Strut(s) in following a load up; however, Struts should **NEVER** be used as a lifting device and only for stabilization.
- When using Stabilization Struts, make sure LockCollars follow the load at all times by adjusting them down as the load is lifted. A LockCollar should never get more than 1" away from the tube body.
- Do not use a hose to carry or move attached equipment. Stress may damage the hose and fittings which could cause personal injury and equipment failure.

## **G3 DUAL DEADMAN OPERATION:**

**NOTE: For safety purposes, all points of connection require the vented coupling Locking Ring to be rotated to the full lock position or the system will leak.**

1. Attach the inlet quick connect nipple on the G3 RSS Controller to a regulated air source.
2. Attach an air hose(s) between the Controller(s) and Strut(s) being used. NOTE: A different colored air hose should be used to permit the rapid and positive identification of the Strut connected to each side of the controller.
3. Turn the pressure regulator adjusting knob clockwise to increase the delivery pressure from 0 psi to 250 psi (17.2 bar).
4. **Slowly** open (turn counter-clockwise) the pressure regulator shut-off valve. The delivery pressure should remain at 250 psi (17.2 bar).
5. Press the green button on the G3 RSS Controller extend the Strut to the required height or pressure. If a second Strut is interconnected to the controller, operate the second green button to extend the second Strut. The Struts may be extended simultaneously or alternately as desired by the operator.
6. To retract a Strut, adjust its height, or relief pressure from the RSS system, press the red button on the G3 RSS Controller.

### **Paratech Incorporated**

P.O. Box 1000, Frankfort, IL 60423 USA

Customer Service: 800.435.9358

Phone: 815.469.3911 Fax: 815.469.7748

www.paratech.com E-mail: [paratech@paratech.us](mailto:paratech@paratech.us)

### **Paratech Europe, Branch of Paratech Inc.**

P.O. Box 174, 5260 Odense S, Denmark

www.paratech.com Email: [Paratech@paratech.dk](mailto:Paratech@paratech.dk)



## **TOOL MAINTENANCE:**

- Gauges should be replaced if the pointer does not return to zero, shows incorrect pressure readings, or the protective cover becomes damaged or cracked. Replacement Procedure:
  1. Using a T20 Torx Driver, remove the 2 screws on the bottom side of the controller that hold the gauge in place and separate the gauge from the controller.

GAUGE INSTALLATION TORX SCREWS

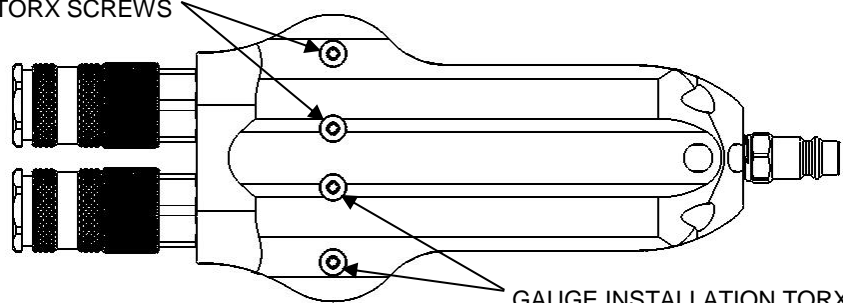

GAUGE INSTALLATION TORX SCREWS

2. Place the flats of the gauge base into a vice and unscrew using a 9/16" (14 mm) open end wrench.

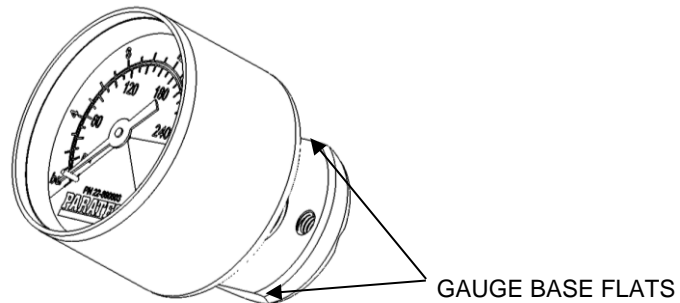

3. Discard the damaged gauge and replace it with PARATECH PN 22-890603.
4. Apply 2 wraps of Teflon tape on the new gauge threads. NOTE: to prevent system contamination keep tape off of the bottom 2 gauge threads.
5. Screw gauge back into the base and retighten until the PARATECH logo on the dial face is parallel with the vice jaws **AND** the gauge threads are flush to slightly recessed with the bottom of the gauge base.

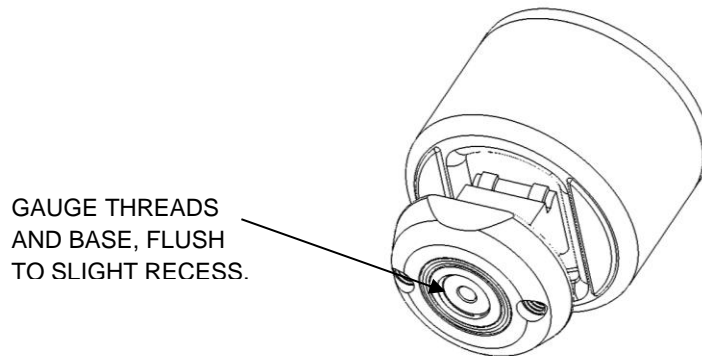

6. Install the gauge back into the controller housing and retighten the T20 Torx screws.

### **Paratech Incorporated**

P.O. Box 1000, Frankfort, IL 60423 USA

Customer Service: 800.435.9358

Phone: 815.469.3911 Fax: 815.469.7748

www.paratech.com E-mail: [paratech@paratech.us](mailto:paratech@paratech.us)

### **Paratech Europe, Branch of Paratech Inc.**

P.O. Box 174, 5260 Odense S, Denmark

www.paratech.com Email: [Paratech@paratech.dk](mailto:Paratech@paratech.dk)



- Gauge Lights can be replaced if the battery dies or the light no longer works. Replacement Procedure:
  1. Using a T20 Torx Driver, remove the 2 screws to the upper left and right of the gauge light.

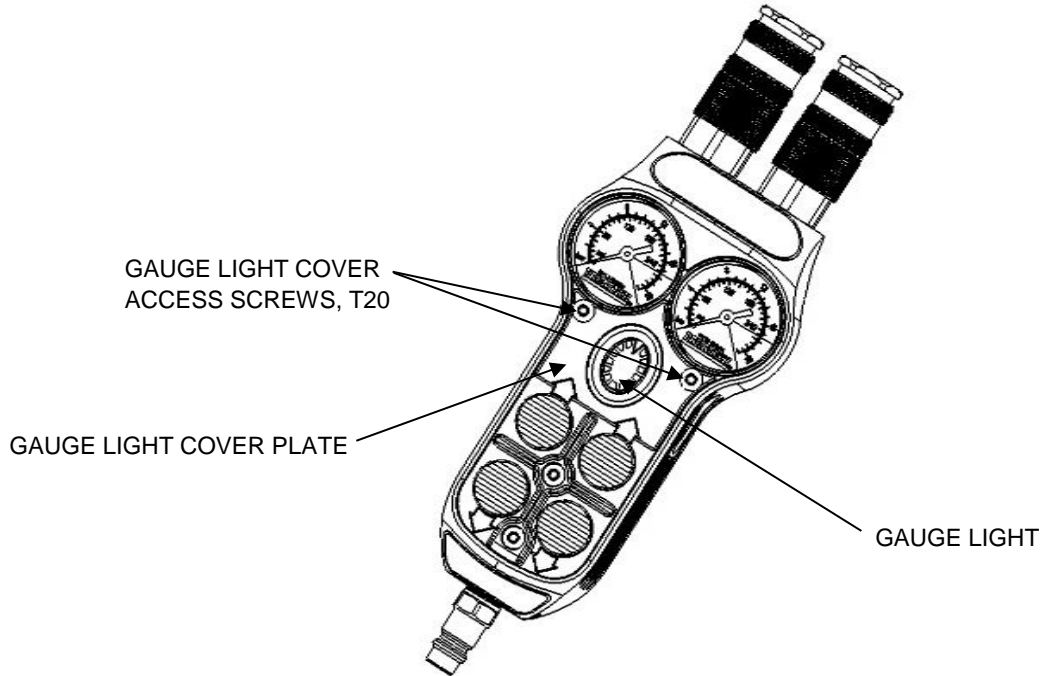

2. Fold back the cover plate to expose the gauge light. NOTE: The cover plate has been designed with a living hinge so it will not be damaged by folding back on itself.
  3. Remove and discard the old gauge light and replace it with PARATECH PN 22-890862.
  4. Fold the cover plate down and reinstall the 2, T20 Torx screws.
- Keep controller free of dirt and debris. To clean, wipe all exposed surfaces with clean warm water and soft cloth.

## G3 DUAL DEADMAN 250 PSI RSS CONTROLLER LIMITED WARRANTY

Each G3 DUAL DEADMAN 250 PSI RSS CONTROLLER or component thereof, manufactured by Paratech Incorporated, has been thoroughly inspected and properly adjusted before shipment to insure the highest quality and the greatest possible reliability.

Paratech Incorporated (hereinafter referred to as "Seller") hereby warrants the G3 DUAL DEADMAN 250 PSI RSS CONTROLLER or component thereof to the original retail buyer only against defects in material and workmanship under normal use and service for a period of five years from the date of purchase. This warranty shall constitute the sole warranty of the Seller with respect to the G3 DUAL DEADMAN 250 PSI RSS CONTROLLER or component thereof. **THE SELLER HEREBY DISCLAIMS AND EXCLUDES ALL OTHER WARRANTIES, EXPRESSED OR IMPLIED, INCLUDING ANY IMPLIED WARRANTY OR MERCHANTABILITY OR FITNESS FOR A PARTICULAR PURPOSE.** The Seller neither assumes nor authorizes any other person to assume for it any other obligations or liabilities in connection with the sale or use of this product.

Should there be any defects in the material or workmanship of the G3 DUAL DEADMAN 250 PSI RSS CONTROLLER, buyer should return the defective product to the factory for inspection with shipping prepaid within five years from the date of purchase. If inspection shows that the G3 DUAL DEADMAN 250 PSI RSS CONTROLLER or a component thereof is defective and that such defects were not caused by negligence, misuse, accident or unauthorized service, the product sold hereunder will be repaired or replaced at the option of the Seller, without charge, FOB at the factory, Frankfort, Illinois.

**THIS REMEDY SHALL BE THE EXCLUSIVE REMEDY FOR BREACH OF WARRANTY WITH RESPECT TO THE G3 DUAL DEADMAN 250 PSI RSS CONTROLLER OR COMPONENTS THEREOF. THE SELLER SHALL NOT BE LIABLE FOR INCIDENTAL OR CONSEQUENTIAL DAMAGES RESULTING FROM ANY BREACH OF WARRANTY WITH RESPECT TO THE G3 DUAL DEADMAN 250 PSI RSS CONTROLLER AND COMPONENTS THEREOF FROM ANY DELAY IN THE PERFORMANCE OF THE REMEDY HEREUNDER.**

# PARATECH®

Paratech Incorporated  
P.O. Box 1000  
Frankfort, IL 60432 USA

Phone: 815.469.3911  
Fax: 815.469.7748  
www.paratech.com  
E-mail: [paratech@paratech.us](mailto:paratech@paratech.us)

**Paratech Incorporated**  
P.O. Box 1000, Frankfort, IL 60423 USA  
Customer Service: 800.435.9358  
Phone: 815.469.3911 Fax: 815.469.7748  
www.paratech.com E-mail: [paratech@paratech.us](mailto:paratech@paratech.us)

**Paratech Europe, Branch of Paratech Inc.**  
P.O. Box 174, 5260 Odense S, Denmark  
www.paratech.com Email: [Paratech@paratech.dk](mailto:Paratech@paratech.dk)

