



- INSTRUCTION SHEET -
HIGH STRENGTH STRUCTURAL KIT (HSSK)

PN: 22-796HSSK

LIST OF COMPONENTS:

- (2) 22-796395 STRUT DISTRIBUTOR MODULE
- (1) 22-796399 TRI-BRACE
- (2) 22-796680 TRI-BASE
- (1) 22-890520 32' HOSE, YELLOW W/COUPLINGS
- (1) 22-890521 32' HOSE, RED W/COUPLINGS
- (1) 22-890522 32' HOSE, BLACK W/COUPLINGS

TOTAL KIT WEIGHT: 67.15lbs (30.46 KG)

FIGURE 1

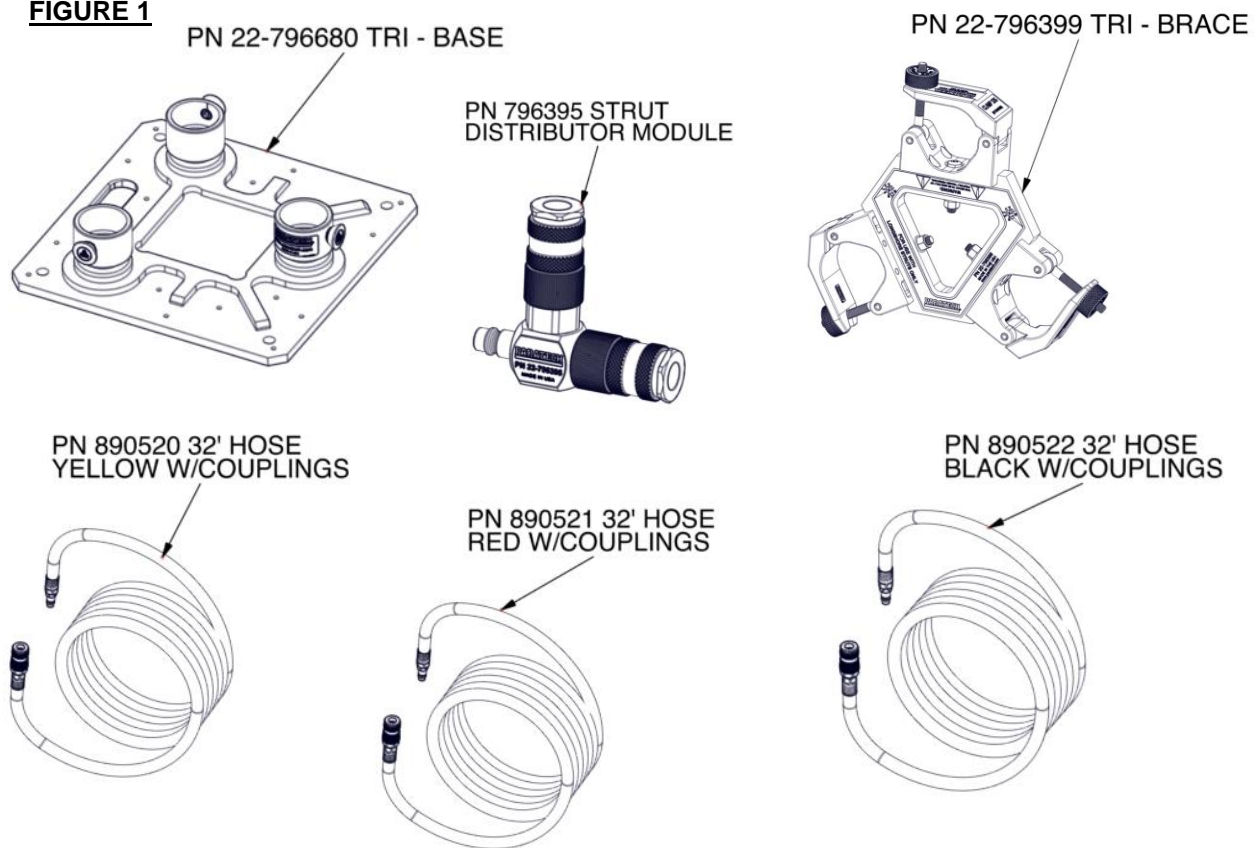

Paratech Incorporated
P.O. Box 1000, Frankfort, IL 60423 USA
Customer Service: 800.435.9358
Phone: 815.469.3911 Fax: 815.469.7748
www.paratech.com E-mail: paratech@paratech.com

Paratech Europe, Branch of Paratech Inc.
P.O. Box 174, 5260 Odense S, Denmark
www.paratech.com Email:
Paratech@paratech.dk



KIT SCHEMATIC:

FIGURE 2:

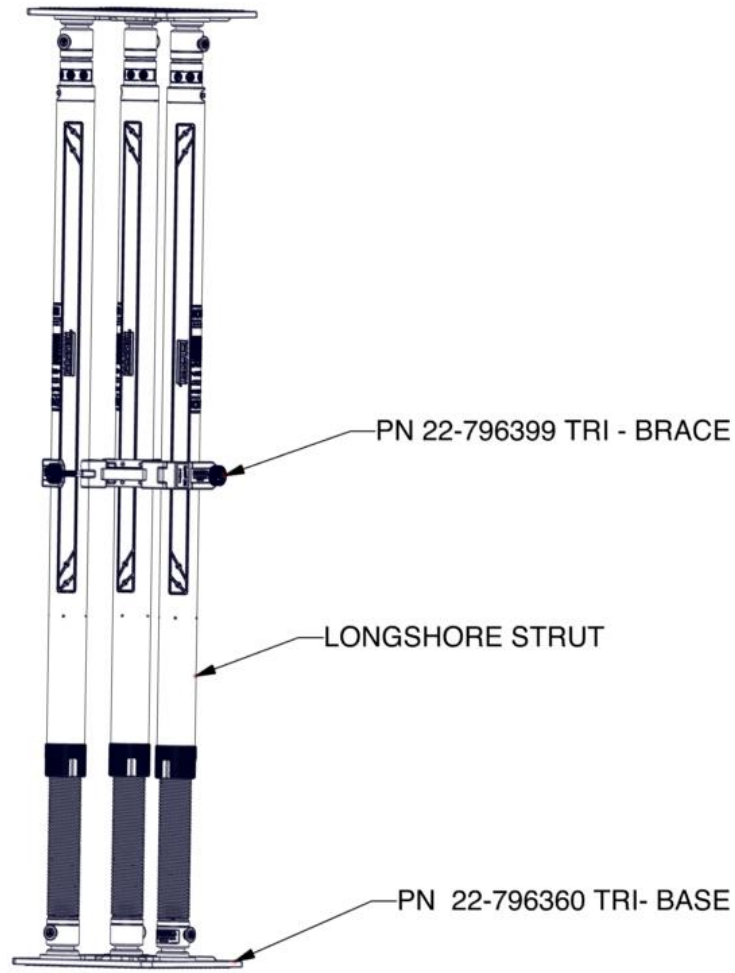

FRONT VIEW

1. Erect supporting structure as shown in Figure 2 on a flat surface, then lift into place. Refer to guidelines in the Paratech Support System Manual for strut load and length parameters.
2. The Tri-Brace must be installed after Struts are installed onto the first Tri-Base.
3. Apply the Tri-Brace to the center point of the system with the clamps attached around the Strut / Extension tube only.
4. Make sure that all bases are placed properly, lock-pins engaged, hose couplings locked, and strut Lock Collars facing down.
5. A Shoring Hammer can be used to tighten Lock Collars on struts to create enough force between the ground and the structure being shored.
6. If using compressed air to extend the struts into place be careful not to apply excessive loads to what is being supported.
7. After the rescue operation is performed, removed air source and use a Shoring Hammer to loosen Lock Collars and disassemble in reverse order.

LOAD RATING:

Maximum Working Load for the assembled system will be 3X the tabulated load data on a LongShore Strut label at the applied length.

MAINTENANCE:

- Inspect kit components for physical damages such as; loose hardware, deep scratches/gouges, surface cracking, cut hose, or leaking couplings.
- To clean, wipe all exposed surfaces with warm, soapy water and soft cloth.

HSSK LIMITED WARRANTY

Each HSSK or component thereof, manufactured by Paratech Incorporated, has been thoroughly inspected and properly adjusted before shipment to insure the highest quality and the greatest possible reliability.

Paratech Incorporated (hereinafter referred to as "Seller") hereby warrants the HSSK or component thereof to the original retail buyer, only against defects in material and workmanship under normal use and service, for 5-years. This warranty shall constitute the sole warranty of the Seller with respect to the HSSK or components thereof. **THE SELLER HEREBY DISCLAIMS AND EXCLUDES ALL OTHER WARRANTIES, EXPRESSED OR IMPLIED, INCLUDING ANY IMPLIED WARRANTY OR MERCHANTABILITY OR FITNESS FOR A PARTICULAR PURPOSE.** The Seller neither assumes nor authorizes any other person to assume for it any other obligations or liabilities in connection with the sale or use of this product.

Should there be any defects in the material or workmanship of the HSSK; the buyer should return the defective product to the factory for inspection with shipping prepaid and a copy of receipt from the date of purchase. If inspection shows that the HSSK or a component thereof is defective and that such defects were not caused by negligence, misuse, accident or unauthorized service, the product sold hereunder will be repaired or replaced at the option of the Seller, without charge, FOB at the factory, Frankfort, Illinois.

THIS REMEDY SHALL BE THE EXCLUSIVE REMEDY FOR BREACH OF WARRANTY WITH RESPECT TO THE HSSK OR COMPONENTS THEREOF. THE SELLER SHALL NOT BE LIABLE FOR INCIDENTAL OR CONSEQUENTIAL DAMAGES RESULTING FROM ANY BREACH OF WARRANTY WITH RESPECT TO THE HSSK OR COMPONENT THEREOF FROM ANY DELAY IN THE PERFORMANCE OF THE REMEDY HEREUNDER.

PARATECH®

PARATECH INCORPORATED
P.O. BOX 1000
1025 LAMBRECHT ROAD
FRANKFORT, ILLINOIS 60423-7000

TELEPHONE (815) 469-3911
FAX (815) 469-7748